



**INSTALLATION MANUAL
OF STANDARD SOLAR
MODULES**

CONTENTS

1.0 GENERAL INFORMATION	3
1.1 INSTALLATION MANUAL DISCLAIMER	3
1.2 LIMITATION OF LIABILITY	3
2.0 SAFETY PRECAUTIONS	3
2.1 INFORMATION PURSUANT TO ART. 33 OF THE REACH REGULATION	4
3.0 MECHANICAL / ELECTRICAL SPECIFICATIONS	4
4.0 UNPACKING AND STORAGE	5
5.0 MODULE INSTALLATION	6
5.1 MODULE WIRING	8
5.2 GROUNDING	11
6.0 MOUNTING INSTRUCTIONS	12
6.1 MOUNTING METHOD: BOLTING	13
6.2 MOUNTING METHOD: CLAMPING	15
6.3 INSERTION SYSTEMS	22
6.4 MOUNTING METHODS WITH SINGLE-AXIS TRACKER	23
7.0 MAINTENANCE	25
8.0 MODULE CLEANING GUIDELINES	25
ANNEX A: MECHANICAL AND ELECTRICAL RATINGS	27
AMENDED EDITIONS AND DATES	39

1.0 GENERAL INFORMATION

This general manual provides important safety information relating to the installation, maintenance and handling of CS-series solar modules.

Professional installer must read these guidelines carefully and strictly follow these instructions. Failure to follow these instructions may result in death, injury or property damage. The installation and handling of PV modules require professional skills and should only be performed by qualified professionals. The installers must inform end-users (consumers) the aforesaid information accordingly. The word "module" or "PV module" used in this manual refers to one or more CS-series solar modules.

This manual is only valid for the standard module types CS1V-MS, CS1VL-MS, CS1A-MS, CS1U-MS, CS1H-MS, CS1K-MS, CS1Y-MS, CS3U-P, CS3U-MS, CS3K-P, CS3K-MS, CS6A-P, CS6A-M, CS6V-P, CS6V-M, CS6K-P, CS6K-M, CS6K-MS., CS6V-MS, CS6VL-MS, CS6A-MS, CS6U-P, CS6U-M, CS3W-P, CS3L-P, CS3W-MS, CS3L-MS, CS3LA-MS, CS3LB-MS, CS1HA-MS, CS3Y-MS, CS3Y-P, CS3N-MS, CS3S-MS, CS6W-MS, CS7L-MS and CS7N-MS.

(Notice: For For KuLite CS3K-P and HiKuLite CS3L-MS-L, a special lightweight option of the standard modules, please refer to the separate Annex E: Mounting Method Clamping for KuLite & HiKuLite.)

Please retain this manual for future reference. We recommend checking www.csisolar.com regularly for the most updated version.

1.1 INSTALLATION MANUAL DISCLAIMER

The information contained in this manual is subject to change by Canadian Solar without prior notice. Canadian Solar gives no warranty of any kind whatsoever, either explicitly or implicitly, with respect to the information contained herein.

In the event of any inconsistency among different language versions of this document, the English version shall prevail. Please refer to our product lists and documents published on our website at: <http://www.csisolar.com> as these lists are updated on a regular basis.

1.2 LIMITATION OF LIABILITY

Canadian Solar shall not be held responsible for damages of any kind, including – without limitation – bodily harm, injury or damage to property, in connection with handling PV modules, system installation, or compliance or non-compliance with the instructions set forth in this manual.

2.0 SAFETY PRECAUTIONS



Warning

Before attempting to install, wire, operate and/or service the module and other electrical equipment, all instructions should be read and understood. PV module connectors pass direct current (DC) when exposed to sunlight or other light sources. Contact with electrically active parts of the module, such as terminals, can result in injury or death, irrespective of whether or not the module and the other electrical equipment have been connected.



Avertissement

Toutes les instructions devront être lues et comprises avant de procéder à l'installation, le câblage, l'exploitation et/ou l'entretien des panneaux. Les interconnexions des panneaux conduisent du courant continu (CC) lorsque le panneau est exposé à la lumière du soleil ou à d'autres sources lumineuses. Tout contact avec des éléments sous tension du panneau tels que ses bornes de sortie peut entraîner des blessures ou la mort, que le panneau soit connecté ou non.

General Safety

All modules must be installed by licensed electricians in accordance to the applicable electrical codes such as, the latest National Electrical Code (USA) or Canadian Electric Code (Canada) or other national or international applicable electrical codes.



Protective clothing (non-slip gloves, clothes, etc.) must be worn during installation to prevent direct contact with 30 V DC or greater, and to protect hands from sharp edges.



Prior to installation, remove all metallic jewelry to prevent accidental exposure to live circuits.



When installing modules in light rain, morning dew, take appropriate measures to prevent water ingress into the connector.



Do not allow children or unauthorized persons near the installation site or module storage area.

- **Do not** install modules in strong wind.
- Use electrically insulated tools to reduce the risk of electric shock.
- If the disconnects and over current protection devices (OCPDs) cannot be opened or the inverter cannot be powered down, cover the fronts of the modules in the PV array with an opaque material to stop the production of electricity when installing or working on a module or wiring.
- **Do not** use or install damaged modules
- Contact with module surfaces or frames may cause electric shock if the front glass is broken or the backsheet is torn.
- The PV module does not contain any serviceable parts. Do not attempt to repair any part of the module.
- Keep the junction box cover closed at all times.
- **Do not** disassemble a module or remove any module part.
- **Do not** artificially concentrate sunlight on a module.
- **Do not** connect or disconnect modules when current from the modules or an external source is present.

2.1 INFORMATION PURSUANT TO ART. 33 OF THE REACH REGULATION

Pursuant to Art. 33 of Regulation (EC) No 1907/2006 of the European Parliament and of the Council of 18 December 2006 concerning the Registration, Evaluation, Authorisation and Restriction of Chemicals (REACH), establishing a European Chemicals Agency, amending

Directive 1999/45/EC and repealing Council Regulation (EEC) No 793/93 and Commission Regulation (EC) No 1488/94 as well as Council Directive 76/769/EEC and Commission Directives 91/155/EEC, 93/67/EEC, 93/105/EC and 2000/21/EC (the "REACH Regulation"), we inform you that our solar modules contain a Substance of Very High Concern ("SVHC") in a concentration above 0.1 % (weight by weight).

The copper ribbons used in our solar modules to interconnect solar cells use a thin solder coating layer that contains lead (CAS no. 7439-92-1).

Under normal or reasonably foreseeable conditions of use, exposure to the lead that is contained in our solar modules can be excluded. However, a release of, and exposure to, lead can take place (i) when the different components of the solar modules are disassembled, in particular for recycling purposes, and (ii) in instances of fire. Lead may damage fertility or the unborn child, causes damage to organs through prolonged or repeated exposure, is very toxic to aquatic life with long lasting effects, may cause cancer, is very toxic to aquatic life, and may cause harm to breast-fed children.

Therefore, recycling and all other types of comparable disassembly of the solar modules have to be performed by a qualified waste management company, in compliance with national and local waste management regulations.

In the instance of fire, please keep away from the fire, and call the local fire brigade.

3.0 MECHANICAL / ELECTRICAL SPECIFICATIONS

Module electrical ratings are measured under Standard Test Conditions (STC) of 1000 W/m² irradiance, with an AM1.5 spectrum, and a cell temperature of 25°C. Detailed electrical and mechanical characteristics of Canadian Solar crystalline silicon PV modules can be found in Annex A (Module Specifications) on www.csisolar.com. Main electrical characteristics at STC are also stated on each module label. Please refer to the datasheet or the product nameplate for the maximum system voltage.

Under certain conditions, a module may produce more

current or voltage than its Standard Test Conditions rated power. As a result, the module short-circuit current under STC should be multiplied by 1.25, and a correction factor should be applied to the open-circuit voltage (see Table 1 below), when determining component ratings and

capacities. Depending on your local regulations, an additional 1.25 multiplier for the short-circuit current (giving a total multiplier of 1.56) may be applicable when sizing conductors and fuses.

Table 1: Low temperature correction factors for open-circuit voltage

Lowest Expected Ambient Temperature (°C/°F)	Correction Factor
24 to 20 / 76 to 68	1.02
19 to 15 / 67 to 59	1.04
14 to 10 / 58 to 50	1.06
9 to 5 / 49 to 41	1.08
4 to 0 / 40 to 32	1.10
-1 to -5 / 31 to 23	1.12
-6 to -10 / 22 to 14	1.14
-11 to -15 / 13 to 5	1.16
-16 to -20 / 4 to -4	1.18
-21 to -25 / -5 to -13	1.20
-26 to -30 / -14 to -22	1.21
-31 to -35 / -23 to -31	1.23
-36 to -40 / -32 to -40	1.25

Alternatively, a more accurate correction factor for the open-circuit voltage can be calculated using the following formula:

$$C_{Voc} = 1 - \alpha_{Voc} \times (25 - T)$$

T is the lowest expected ambient temperature at the system installation site.

α_{Voc} (%/°C) is the voltage temperature coefficient of the selected module (refer to corresponding datasheet).

Electrical calculations and design must be performed by a competent engineer or consultant.

Please contact Canadian Solar's technical support team for additional information pertaining to engineering optimization and approval of project specific module string lengths.

4.0 UNPACKING AND STORAGE

NOTICE

PRECAUTIONS

- Modules should be stored in a dry and ventilated environment to avoid direct sunlight and moisture. If

modules are stored in an uncontrolled environment, the storage time should be less than 3 months and extra precautions should be taken to prevent connectors from being exposed to moisture or sunlight, like using connector endcaps.

- When unloading modules pallets from containers, please use a fork lift to remove the module pallets, and the forklift should be close to the ground in order to avoid the top of module pallets touching the top of the cabinet door. The thickness of forklift teeth should be less than 75mm, and the length of the forklift teeth should be longer than 2300mm. For unloading CS7N-MS and CS7L-MS modules, the length of the forklift teeth should be longer than 1250mm and the width of forklift teeth should be wider than 700mm (from outer edge to outer edge).
- Unpack module pallets carefully, following the steps shown on the pallet. Unpack, transport and store the modules with care.
- Modules must always be unpacked and installed by two people. Always use both hands when handling modules.



- **Do not** lift modules by their wires or junction box, lift them by the frame.
- Stacks of modules should contain no more than 12 modules, and the frames should be aligned.
- **Do not** place excessive loads on the module or twist the module frame.
- **Do not** stand, step, walk and/or jump on modules under any circumstances. Localized heavy loads may cause severe micro-cracks at cell level, which in turn may compromise module reliability and void Canadian Solar's warranty.



- **Do not** support the module by the backsheet when handling or installing the module.
- **Do not** carry modules on your head.
- **Do not** drop or place objects (such as tools) on the modules.
- **Do not** use sharp instruments on the modules. Particular care should be taken to avoid module backsheets being damaged by sharp objects, as scratches may directly affect product safety.
- **Do not** leave modules unsupported or unsecured.
- **Do not** change the wiring of bypass diodes.
- Keep all electrical contacts clean and dry at all times.
- **Do not** expose the modules and its electrical contacts to any unauthorized chemical substance (e.g. oil, lubricant, pesticide, etc.).

PRODUCT IDENTIFICATION

Each module has three identical barcodes (one in the laminate under the front glass, the second on the rear side of the module and the third on the frame) that act as a unique identifier. Each module has a unique serial number containing 13 (pre-March 2013) or 14 (post-March 2013) digits.

A nameplate is also affixed to the rear of each module. This nameplate specifies the model type, as well as the main electrical and safety characteristics of the module.

5.0 MODULE INSTALLATION



PRECAUTIONARY MEASURES AND GENERAL SAFETY

- Prior to installing modules please obtain information about any requirements and necessary approvals for the site, installation and inspection from the relevant authorities.
- Check applicable building codes to ensure that the construction or structure (roof, facade, support, etc.) can bear the module system load.
- Canadian solar modules have been qualified for Application Class A (equivalent to Safety Class II requirements). Modules rated under this class should be used in systems operating at voltage above 50V or power above 240W, where general contact access is anticipated.
- Canadian Solar standard modules have been certified as Type 1 or Type 4 according to UL 1703, Type 1 or Type 2 according to UL 61730 and Class C according to IEC 61730-2 for fire class performance, please refer to the datasheet or the product nameplate for the detailed types.
- Consult your local authority for guidelines and requirements for building or structural fire safety.

UL 1703 SYSTEM FIRE RATING REQUIREMENTS

- Photovoltaic systems composed of UL 1703 or UL 61730 certified modules mounted on a UL 2703 certified mounting system should be evaluated in combination with roof coverings in accordance with UL 1703 or UL

61730 standard, with respect to meeting the same fire classification as the roof assembly.

- Mounting systems with a System Fire Class Rating (Class A, B or C), tested in conjunction with “Type 1” or “Type 2” or “Type 4” fire rated modules, are considered acceptable for use with Canadian Solar modules, provided that the mounting system does not violate any other requirements of this manual.
- Any mounting system limitations on inclination or accessories required to maintain a specific System Fire Class Rating should be clearly specified in the installation instructions and UL 2703 certification of the mounting system supplier.
- When installing modules, ensure the assembly is mounted over a fire resistant roof covering rated for the application.
- The fire rating for this module is only valid when the product is installed as specified in the mechanical mounting instructions.

ENVIRONMENTAL CONDITIONS

- The module is intended for use in general open-air climates, as defined in IEC 60721-2-1: Classification of environmental conditions Part 2-1: Environmental conditions appearing in nature. Temperature and humidity.
- Please consult the Canadian Solar technical support department for more information on the use of modules in special climates, such as an altitude greater than 2000m.



Do not install modules near open flames or flammable materials.



Do not immerse modules in water or constantly expose modules to water (either fresh or salt, i.e. from fountains, sea spray).

- Exposing modules to salt (i.e. marine environments) or sulfur (i.e. sulfur sources, volcanoes) incurs the risk of module corrosion.
- Do not expose modules and their connectors to any unauthorized chemical substances (e.g. oil, lubricant, pesticide, etc.), as modules may incur damages.

- Failure to comply with these instructions will void Canadian Solar warranty.
- Canadian solar modules have passed salt mist corrosion resistance test according to IEC 61701, but the corrosion may still occur on where the modules frame is connected to the bracket or where the grounding is connected. Should the installation location be near the ocean, Canadian solar recommends stainless steel or aluminum materials be used in the areas with direct contact with the PV modules, and the connection point should be protected with anti-corrosion measures. For more information, please contact Canadian solar technical support team.
- CS7L-MS & CS7N-MS modules, when used in rooftop applications, should be installed in a way that ensures enough ventilation. The clearance between lowest point of module and the roof surface MUST be equal to or greater than 102 mm, tilt angle of module to roof surface should be equal to or greater than 15°, and wind shields or decorative sheets which will prevent ventilation around PV array are NOT allowed to be installed.

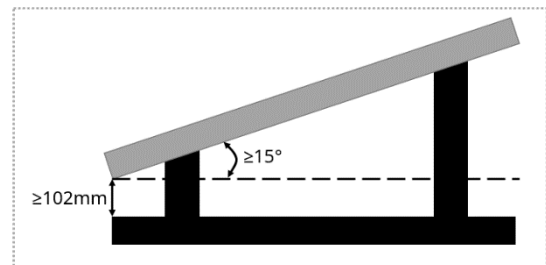

INSTALLATION REQUIREMENTS

- Ensure that the module meets the general technical system requirements.
- Ensure that other systems components do not damage the module mechanically or electrically.
- Modules can be wired in series to increase voltage or in parallel to increase current. To connect modules in series, connect the cables from the positive terminal of one module to the negative terminal of the next module. To connect in parallel, connect the cables from the positive terminal of one module to the positive terminal on the next module.

- The quantity of bypass diodes in the module's junction box provided may vary depending on the model series.
- Only connect the quantity of modules that corresponds to the voltage specifications of the inverters used in the system. In addition modules must not be connected together to create a voltage higher than the maximum permitted system voltage stated on the module nameplate, even under the worst local temperature conditions (see Table 1 for the correction coefficients that apply to open-circuit voltage).
- A maximum of two strings can be connected in parallel without using an over-current protection device (fuses, etc.) incorporated in series within each string. Three or more strings can be connected in parallel if an appropriate and certified over-current protection device is installed in series within each string. And it shall be ensured in the PV system design that the reverse current of any particular string is lower than the module maximum fuse rating at any circumstances.
- Only modules with similar electrical parameters should be connected in the same string to avoid or minimize mismatch effects in arrays.
- To minimize risk in the event of an indirect lightning strike, avoid forming loops with the wiring when designing the system.
- The recommended maximum series fuse rating is stated in a table in the Annex A.
- Modules should be safely fixed to bear all expected loads, including wind and snow loads.
- A minimum clearance of 6.5 mm (0.25 in) between modules is required to allow for thermal expansion of the frames.
- The small drainage holes on the underside of the module must not be blocked.

OPTIMUM ORIENTATION AND TILT

- To maximize the annual yield, please calculate the optimum orientation and tilt for PV modules in that specific installation site. The highest yields are achieved when sunlight shines perpendicularly onto the PV modules.

AVOID SHADING

- Even minor partial shading (e.g. from dirt deposits) reduces yields. A module can be considered to be unshaded if its entire surface is free from shading all year round. Sunlight should be able to reach at least the module even on the shortest day of the year.
- Constant shading conditions can affect module service lifetime, due to accelerated ageing of the encapsulation material and thermal stress on the bypass diodes.

RELIABLE VENTILATION

- Sufficient clearance (at least 102 mm (4.02 in)) between the module frame and the mounting surface is required to allow cooling air to circulate around the back of the module. This also allows condensation or moisture to dissipate.
- According to UL 1703, any other specific clearance required for maintaining a system fire rating should prevail. Detailed clearance requirements pertaining to system fire ratings must be provided by your racking supplier.

5.1 MODULE WIRING

CORRECT WIRING SCHEME

- Cable management scheme should be reviewed and approved by the EPC contractor; in particular required cable lengths should be cross-checked considering the specificities of the tracker structure like bearing house gaps. If longer cable or additional jumper cable is requested, please contact Canadian Solar's sales representative in advance.
- Ensure that the wiring is correct before starting up the system. If the measured open circuit voltage (Voc) and short-circuit current (Isc) differ from the specifications, this indicates that there is a wiring fault.
- When modules have been pre-installed but the system has not been connected to the grid yet, each module string should be kept under open-circuit conditions and proper actions should be taken to avoid dust and moisture penetration inside the connectors.
- Do not connect different connectors (brand and model)

together.

- In case where a cable connection method not included in the below table is used, please confirm the suitable cable length with Canadian Solar's sales representative.

- For different CSI module types, Canadian Solar offers optional cable specifications lengths to match various system configurations. Recommended system cable schemes are shown in table 2 & 3 below

Table 2: System Cable Scheme for CS3U/CS3K/CS3W/CS3L/CS3LA/CS3LB/CS3Y/CS3N/CS3S/CS6W/CS7N/CS7L modules

Module types	Standard cables
<p>CS3U-P, CS3U-MS, CS3K-P, CS3K-MS, CS3W-P, CS3W-MS, CS3L-P, CS3L-MS, CS3LA-MS, CS3LB-MS CS3Y-P, CS3Y-MS, CS3N-MS, CS3S-MS, CS6W-MS, CS7N-MS, CS7L-MS</p>	<div style="text-align: center;">  <p>Portrait two rows installation</p> <p>Note: Adjacent two modules (up and down) need to be rotated 180 degrees</p> </div> <hr/> <div style="text-align: center;">  <p>Portrait one row installation</p> </div> <hr/> <div style="text-align: center;">  <p>Landscape installation</p> <p>Note: Adjacent two modules (left to right) need to be rotated 180 degrees</p> </div>
<p>CS3U-P, CS3U-MS, CS3K-P, CS3K-MS, CS3W-P, CS3W-MS, CS3L-P, CS3L-MS, CS3LA-MS, CS3LB-MS CS3Y-P, CS3Y-MS, CS3N-MS, CS3S-MS, CS6W-MS</p>	<div style="text-align: center;">  <p>Leap-frog</p> </div>

Table 3: System Cable Scheme for CS1V/CS1VL/CS1A/CS1H/CS1K/CS1HA/CS1U/CS1Y modules

Module types	Standard cables
<p>CS1V-MS, CS1VL-MS, CS1A-MS, CS1H-MS, CS1K-MS, CS1HA-MS, CS1U-MS, CS1Y-MS</p>	 <p>Portrait two rows installation Note: Adjacent two modules (left to right) need to be rotated 180 degrees</p>
	 <p>Portrait one row installation Note: Adjacent two modules (left to right) need to be rotated 180 degrees</p>
	 <p>Landscape installation Note: Adjacent two modules (up and down) need to be rotated 180 degrees</p>
	 <p>Leapfrog</p>

The maximum distance between two adjacent module frames should be within 50 mm (1.96in) for the side with mounting clamps, and within 25 mm (0.98in) for the side without mounting clamps, in order to meet the system cable scheme.

CORRECT CONNECTION OF CONNECTORS

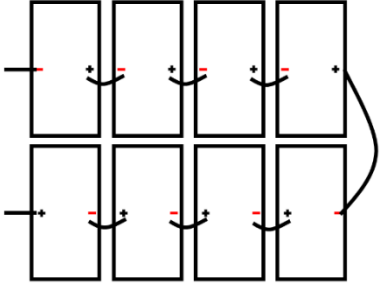
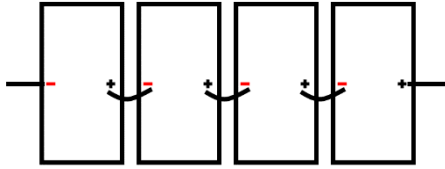
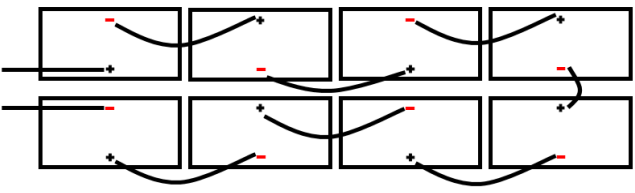
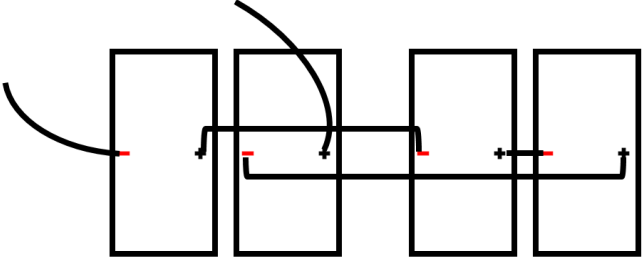
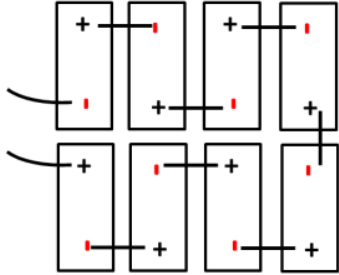
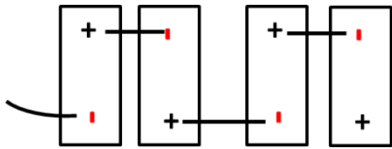
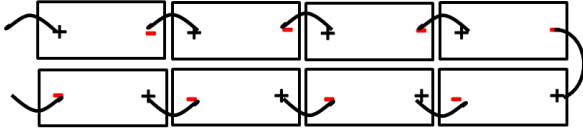
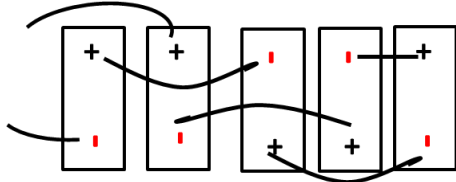
- Make sure that all connections are safe and properly mated. The PV connector should not be subject to stress from the exterior. Connectors should only be used to connect the circuit. They should never be used to turn the circuit on and off.
- Connectors are not waterproof when unmated. When installing modules, connector should be connected to each other as soon as possible or appropriate measures (like using connector endcaps) should be taken to avoid moisture and dust penetrating into the connector.
- Do not clean or precondition the connectors using lubricants or any unauthorized chemical substances.

USE OF SUITABLE MATERIALS

- Only use dedicated solar cable and suitable connectors (wiring should be sheathed in a sunlight-resistant conduit or, if exposed, should itself be sunlight-resistant) that meet local fire, building and electrical regulations. Please ensure that all wiring is in perfect electrical and mechanical condition.
- Installers may only use single-conductor cable listed and labeled as USE-2 or PV wire which is 90°C wet rated in North America, and single conductor cable, 2.5-16 mm² (5-14 AWG), 90°C wet rated in other areas (i.e. TUV 2PFG1169 or EN50618 approved), with proper insulation which is able to withstand the maximum possible system open-circuit voltage.
- Only copper conductor material should be used. Select a suitable conductor gauge to minimize voltage drop and ensure that the conductor ampacity complies with local regulations (i.e. NEC 690.8(D)).

Cable and connector protection

- Secure the cables to the mounting system using UV-resistant cable ties. Protect exposed cables from damage by taking appropriate precautions (e.g. placing them inside a metallic raceway like EMT conduit). Avoid exposure to direct sunlight.
- A minimum bending radius of 60 mm (2.36 in) is required when securing the junction box cables to the

racking system.

- Protect exposed connectors from weathering damage by taking appropriate precautions. Avoid exposure to direct sunlight.
- Do not place connectors in locations where water could easily accumulate.

5.2 GROUNDING

- For grounding requirements in North America, a module with exposed conductive parts is considered to comply with UL 1703 only when it is electrically grounded in accordance with both the instructions presented below and the requirements of the National Electrical Code. Any grounding means used with Canadian Solar modules should be NRTL certified to UL 467 and UL 2703 standards. Please consult our technical service team for the formal approval process.
- For grounding requirements in other areas, although the modules are certified to Safety Class II, we recommend them to be grounded and that module installation should comply with all applicable local electrical codes and regulations. Grounding connections should be installed by a qualified electrician. Connect module frames together using adequate grounding cables: we recommend using 4-14 mm² (AWG 6-12) copper wire. Holes provided for this purpose are identified with a grounding symbol  (IEC 61730-1). All conductive connection junctions must be firmly fixed.
- Do not drill any extra ground holes for convenience as this will void the modules warranty.
- All bolts, nuts, flat washers, lock washers and other relevant hardware should be made of stainless steel, unless otherwise specified.
- Canadian Solar does not provide grounding hardware.
- The grounding method described below is recommended for Canadian Solar.

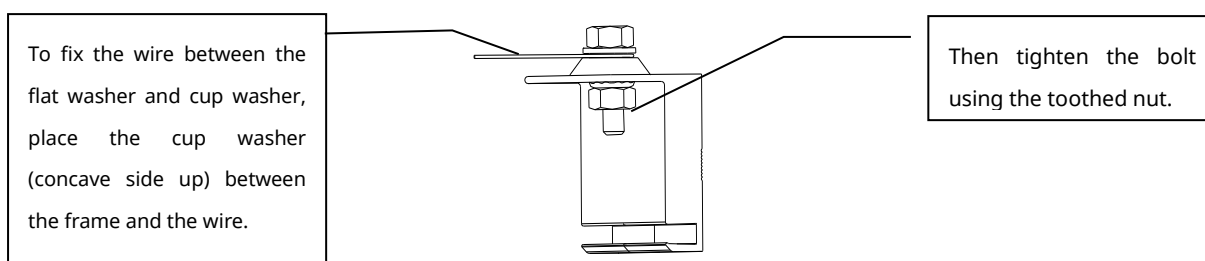
GROUNDING METHOD: BOLT + TOOTHED NUT + CUP WASHER.

- A grounding kit containing an M5 (3/16") SS cap bolt, an M5 (3/16") SS flat washer, an M5 (3/16") SS cup washer, and an M5 (3/16") SS nut (with teeth) is used to attach copper grounding wire to a pre-drilled grounding hole on the frame (see image above).
- Place the wire between the flat washer and the cup washer. Ensure that the cup washer is positioned between the frame and the wire with the concave side up to prevent galvanic corrosion. Tighten the bolt securely using the SS toothed nut. A wrench may be used to do this. The tightening torque is 3-7 Nm (2.2-5.2 ft-lbs).

6.0 MOUNTING INSTRUCTIONS

The applicable regulations pertaining to work safety, accident prevention and securing the construction site must be observed. Workers and third party personnel shall wear or install fall arrest equipment. Any third party need to be protected against injuries and damages.

- The mounting design must be certified by a registered professional engineer. The mounting design and procedures must comply with all applicable local codes and requirements from all relevant authorities.
- The module is considered to be in compliance with UL 1703 or UL 61730 and IEC 61215 only when the module is mounted in the manner specified by the mounting instructions included in this installation manual.
- The system designer and installer are responsible for load calculations and for proper design of support structure.
- Any module without a frame (laminate) shall not be considered to comply with the requirements of UL 1703 or UL 61730 unless the module is mounted with hardware that has been tested and evaluated with the module under this standard or by a field Inspection certifying that the installed module complies with the requirements of UL 1703 or UL 61730.
- Canadian Solar does not provide mounting hardware.
- Standard modules can be mounted onto a support structure using one of several approved methods as described below. For information about other installation methods, please contact your local representative. Failure to use a recognized installation method will void the Canadian Solar warranty.
- Use appropriate corrosion-proof fastening materials. All mounting hardware (bolts, spring washers, flat washers, nuts) should be hot dip galvanized or stainless steel.
- Use a torque wrench for installation.
- Do not drill additional holes or modify the module frame. Doing so will void the warranty.
- Standard modules can be installed in either landscape or portrait orientations. Refer to the detailed instructions for further guidance. Please note that in areas with heavy snowfall (> 2400 Pa) further countermeasures such the use of additional support bars should be considered to avoid snow loads damaging the lowest row of modules.
- In cases where an additional support bar is recommended to improve both mechanical stability and long-term module performance, we recommend selecting a sufficiently resistant material. Canadian Solar recommends bars with a minimum thickness of

50 mm (1.97 in). The support bar centerline should be positioned within 100 mm (3.94 in) of the side frame centerline (slight shifts may be necessary to access module grounding holes).

- The loads described in this manual correspond to test loads. For installations complying with IEC 61215-2:2016 and UL 1703 or UL 61730, a safety factor of 1.5 should be applied for calculating the equivalent maximum authorized design loads. Project design loads depend on construction, applicable standards, location and local climate. Determination of the design loads is the responsibility of the racking suppliers and/or professional engineers. For detailed information, please follow local structural code or contact your professional structural engineer.

6.1 MOUNTING METHOD: BOLTING

- The mechanical load test with these mounting methods were performed according to IEC 61215.
- Modules should be bolted to supporting structures through the mounting holes in the rear frame flanges only.
- Each module must be securely fastened at a minimum of 4 points on two opposite sides.
- M8 X 1.25 - Grade 8.8 (5/16"-18 Grade B7) galvanized or A2-70 stainless steel bolt and nut should be used.

- The yield strength of bolt and nut should not be less than 450MPa.
- Tightening torques should be 16~20 Nm (11.8~14.75 ft-lbs) for M8 (5/16"-18) coarse thread bolts, depending on bolt class.
- In areas with heavy wind loads, additional mounting points should be used. The system designer and the installer are responsible for correctly calculating the loads and ensuring that the supporting structure meets all the applicable requirements.

Mounting method: Bolting

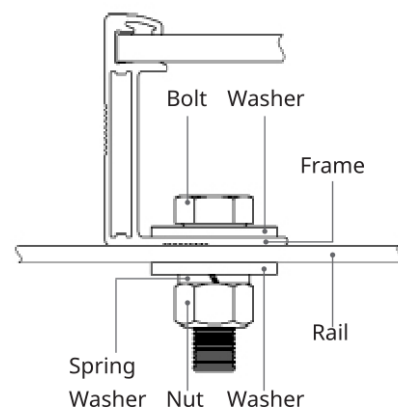

- Modules should be bolted at the following hole locations depending on the configuration and loads:

Table 5: Approved bolting methods

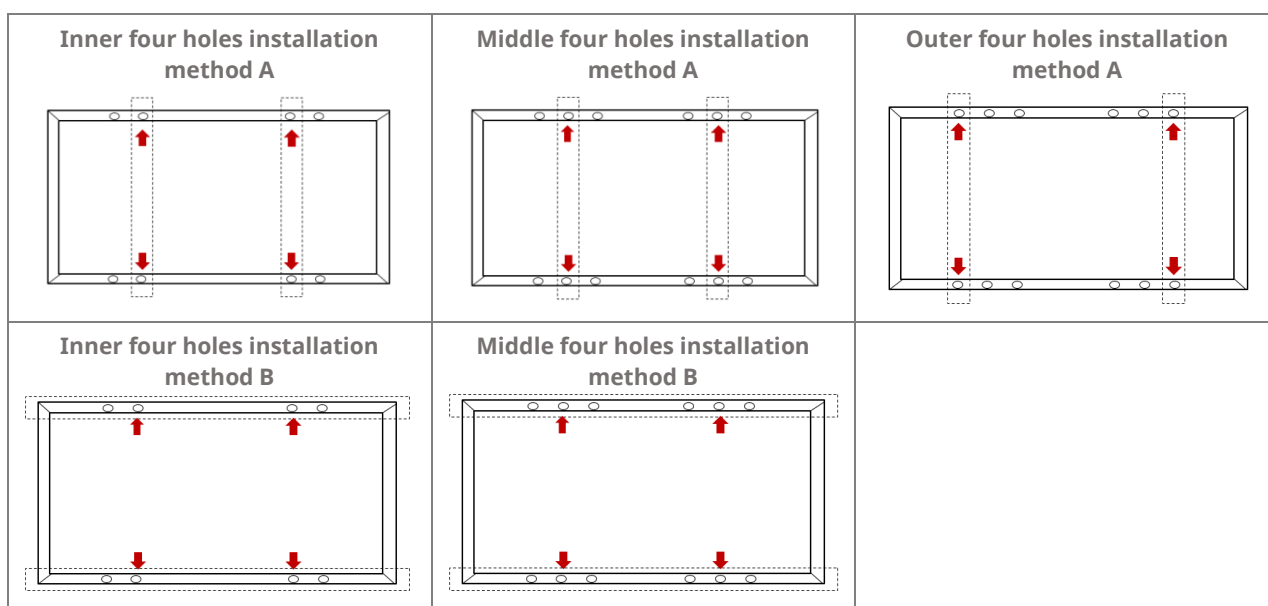

Installation Method / Module Types	Inner four holes installation method A	Inner four holes installation method B	Middle four holes installation method A	Middle four holes installation method B	Outer four holes installation method A
CS1V/CS1VL/CS1A/ CS3K/CS6A/CS6V/ CS6K/CS6VL/CS1HA	+5400Pa/- 2400Pa	+4000Pa/- 2400Pa	/	/	/
CS3U/CS6U	/	/	+5400Pa/- 2400Pa	+5400Pa/- 2400Pa	/
CS3W/CS1U	/	/	+5400Pa/- 2400Pa	+3600Pa/- 2400Pa	/
CS3L/CS3LA/CS3LB / CS1H/CS1K	+5400Pa/- 2400Pa	/	/	/	/
CS1Y	+5400Pa/- 2400Pa	+5400Pa/- 2400Pa	/	/	/
CS3Y/CS3N/CS3S/ CS6W/CS7L/CS7N	/	/	/	/	+5400Pa/- 2400Pa

Note: The installation method of bolt is based on the experimental results, "/" means not tested.

6.2 MOUNTING METHOD: CLAMPING

- The mechanical load test with these mounting methods were performed according to IEC 61215.
- Top or bottom clamping methods will vary and are dependent on the mounting structures. Please follow the mounting guidelines recommended by the mounting system supplier.
- Each module must be securely fastened at a minimum of four points on two opposite sides. The clamps should be positioned symmetrically. The clamps should be positioned according to the authorized position ranges.
- Install and tighten the module clamps to the mounting rails using the torque stated by the mounting hardware manufacturer. M8 X 1.25 (5/16") bolt and nut are used for this clamping method.
- Tightening torques should be within 16~20 Nm (11.8~14.75 ft-lbs) for M8 (5/16") coarse thread bolts, depending on the bolt class. For the bolt grade, the technical guideline from the fastener suppliers should be followed. Different recommendations from specific clamping hardware suppliers should prevail.
- The system designer and installer are responsible for load calculations and for proper design of support structure.
- Canadian Solar's warranty may be void in cases where improper clamps or unsuitable installation methods are found. When installing inter-modules or end-type clamps, please take the following measures into account:

1. Do not bend the module frame.
2. Do not touch or cast shadows on the front glass.
3. Do not damage the surface of the frame (to the exception of the clamps with bonding pins).
4. Ensure the clamps overlap the module frame by at least 10 mm (0.4 in) for CS6W, CS7N and CS7L, 5mm (0.2in) for others.
5. Overlap in length by at least
 - a) 80 mm (3.15 in) when uplift load > 2400 Pa is required.
 - b) 40 mm (1.57 in) when uplift load ≤ 2400 Pa is required.

6. Ensure the clamp thickness is at least 3 mm (0.12 in).

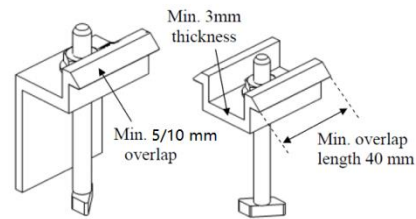

- Clamp material should be anodized aluminum alloy or stainless steel.
- Clamp positions are of crucial importance for the reliability of the installation. The clamp centerlines must only be positioned within the ranges indicated in table below, depending on the configuration and load. For configurations where the mounting rails run parallel to the frame, precautions should be taken to ensure the bottom flange of the module frame overlaps the rail by 15 mm (0.59 in) or more.

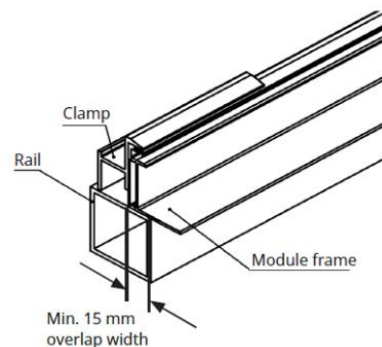

6.2.1 Four clamps on long side of frame and rails perpendicularly to the long side frame

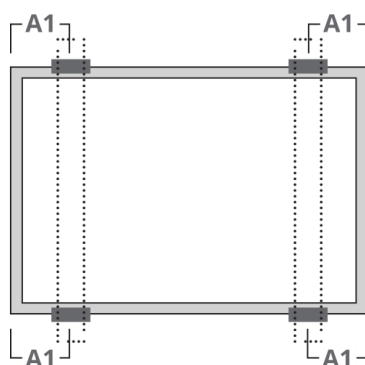

Module Types	Max Mechanical Load (Pa)					
	+2000/ -2000	+2400/ -2400	+3600/ -2400	+5400/ -2400	+5400/ -3600	+7000/ -5400
	A1 Range (mm)					
CS1H	0-219	220-440	/	/	270-330	/
CS6A/CS6VL/CS1VL/CS1HA/CS1A	0-219	220-440	/	270-330	/	/
CS1V	0-239	331-550	/	240-330	/	/
CS3K/CS6K/CS1K/CS6V	0-239	331-550	/	/	240-330	/
CS3U/CS6U/CS3W	/	340-550	/	/	410-490	/
CS1U	/	340-550	/	410-490	/	/
CS1Y	/	/	300-600	/	350-550	400-500
CS3L/CS3LA/CS3LB	/	331-550	/	/	240-330	/
CS3Y/CS6W/CS3N/CS7L/CS7N	/	300-600	/	400-500	/	/
CS3S	/	/	300-600	400-500	/	/

6.2.2 Four clamps on short side of frame and rails perpendicular to the long side frame.

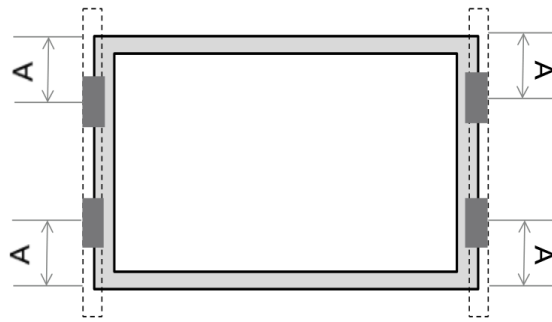

Module Types	A Range (mm)	
	0-200	200-250
	Max Mechanical Load (Pa)	
CS3U/CS6U	+1200/-1200	+1400/-1400
CS3W	+1000/-1000	+1200/-1200
CS3L	+2000/-2000	+2200/-2200
CS1Y	+1600/-1600	+1800/-1800
CS3N	+1400/-1400	+1600/-1600

6.2.3 Four clamps on long side of frame and rails parallel to the long side frame.

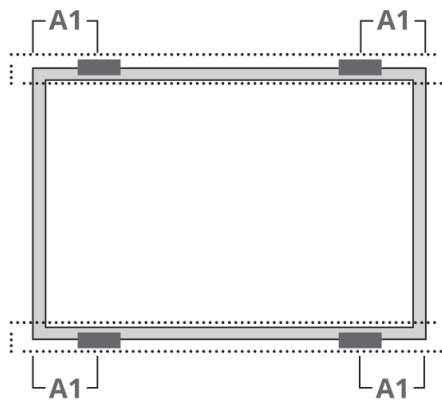

Module Types	Max Mechanical Load (Pa)	
	+4000/-2400	+5400/-2400
	A1 Range (mm)	
CS3U	/	410-490
CS3K/CS1V/CS6V	240-330	/
CS1VL/CS1A/CS1HA/CS6A/CS6VL	270-330	/

6.2.4 Two clamps on the long side and two clamps on the short side of frame. Rails run perpendicular to the long side frame.

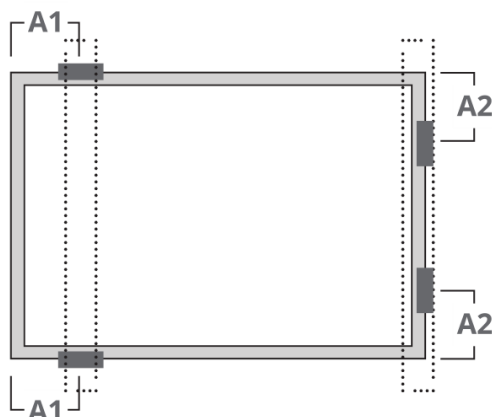

Module Types	Max Mechanical Load (Pa)	
	+2400/-2400	
	A1 Range (mm)	A2 Range (mm)
CS3U/CS6U	300-550	200-250
CS3K	100-550	200-250

6.2.5 Four clamps on short side of frame and rails parallel to the long side frame.

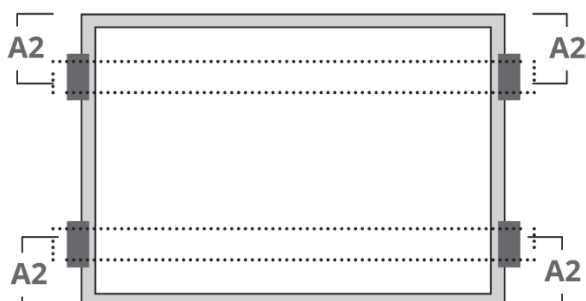

Module Types	Max Mechanical Load (Pa)		
	+2000/-2000	+2200/-2200	+2400/-2400
	A2 Range (mm)		
CS1VL/CS1A/CS1HA/CS6A/CS6VL	/	/	200-250
CS1V/CS6V	/	/	170-210
CS3K	200-250	/	/
CS3L	/	230-250	/

6.2.6 Four clamp mounting on short side of frame.

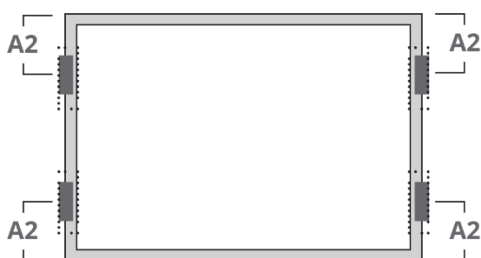

Module Types	Max Mechanical Load (Pa)		
	+2000/-2000	+2200/-2200	+2400/-2400
	A2 Range (mm)		
CS1VL/CS1A/CS1HA/CS6A/CS6VL	/	/	0-250
CS1V/CS6V	0-210	/	/
CS3K	0-200	200-250	/

6.2.6 Four clamp mounting on short side of frame, and an additional support bar placed below the center of the module.

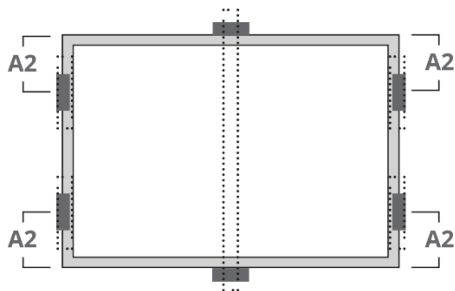

Module Types	Max Mechanical Load (Pa)	
	+5400/-2400	
	A2 Range (mm)	
CS1VL/CS1A/CS1HA/CS3K/CS3U/CS6A/CS6VL	200-250	
CS1V/CS6V	170-210	

6.2.7 Six clamps on long side of frame and rails perpendicularly to the long side frame

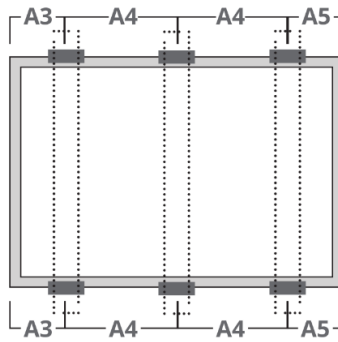

Module Types	Max Mechanical Load (Pa)		
	+5400/-2400	+5400/-3600	+6000/-4000
	A3 & A5 Range (mm)		
CS1K/CS1H	80-380	/	0-250
CS1U	250-350	/	/
CS3L	/	140-440	/
CS3K/CS6A/CS6VL/CS6V	/	/	80-380

6.2.8 Rail-less clamping

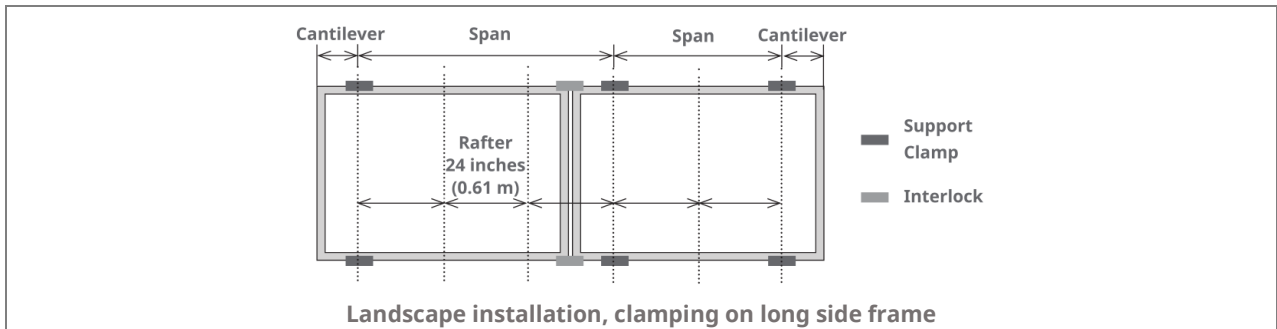

Landscape installation, clamping on long side frame

Module Type	Max Span	Max Cantilever length	Downforce	Uplift
CS3K/CS6K/CS1K/CS1H	72 inches (1.83 m)	24 inches (0.61 m)	2200 Pa	1400 Pa
	64 inches (1.63 m)	21.3 inches (0.54 m)	2400 Pa	1400 Pa
	48 inches (1.22 m)	16 inches (0.41 m)	3400 Pa	1800 Pa
	32 inches (0.81 m)	10.7 inches (0.27 m)	4800 Pa	2400 Pa
CS1Y	72 inches (1.83 m)	24 inches (0.61 m)	2650 Pa	2400 Pa
	64 inches (1.63 m)	21.3 inches (0.54 m)	2800 Pa	2400 Pa
	48 inches (1.22 m)	16 inches (0.41 m)	3850 Pa	3600 Pa
	32 inches (0.81 m)	10.7 inches (0.27 m)	5400 Pa	3600 Pa
CS3N	72 inches (1.83 m)	24 inches (0.61 m)	2200 Pa	2200 Pa
	64 inches (1.63 m)	21.3 inches (0.54 m)	2400 Pa	2200 Pa
	48 inches (1.22 m)	16 inches (0.41 m)	3000 Pa	2400 Pa
	32 inches (0.81 m)	10.7 inches (0.27 m)	3600 Pa	3600 Pa

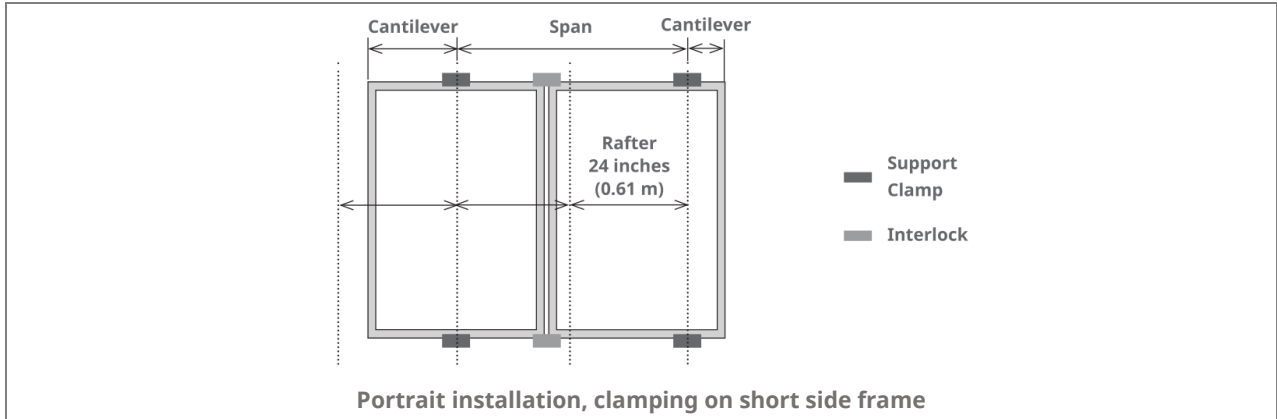

Module Type	Max Span	Max Cantilever length	Downforce	Uplift
CS3K/CS6K/CS1K/CS1H	48 inches (1.22 m)	16 inches (0.41 m)	1800 Pa	800 Pa
	32 inches (0.81 m)	10.7 inches (0.27 m)	1800 Pa	1200 Pa
	24 inches (0.61 m)	8 inches (0.2 m)	1800 Pa	1800 Pa
CS1Y	48 inches (1.22 m)	16 inches (0.41 m)	1800 Pa	1800 Pa
	32 inches (0.81 m)	10.7 inches (0.27 m)	1800 Pa	1800 Pa
	24 inches (0.61 m)	8 inches (0.2 m)	2000 Pa	2000 Pa
CS3N	48 inches (1.22 m)	16 inches (0.41 m)	1600 Pa	1600 Pa
	32 inches (0.81 m)	10.7 inches (0.27 m)	1600 Pa	1600 Pa
	24 inches (0.61 m)	8 inches (0.2 m)	1800 Pa	1800 Pa

6.3 INSERTION SYSTEMS

- This mounting method has been certified by VDE and CSA, or qualified by Canadian Solar.
- Insertion methods can vary and depend on the mounting structures. The installer needs to follow the mounting guidelines recommended by the mounting system supplier. Each module must be securely maintained through all its length on two opposite sides. Install and tighten the insertion profiles to the support structure using the hardware and instructions provided by the mounting system manufacturer. The system designer and installer are solely responsible for load calculations and for the proper design of support structure.
- Canadian Solar warranty may be void in cases where improper insertion systems or unsuitable installation methods are found. When installing insertion profiles, please take the following measures into account:

1. Do not bend the module frame.
2. Do not touch the front glass or cast shadow onto it.
3. Do not damage the surface of the frame.
4. Ensure that the insertion profiles overlap the module frame by at least 10 mm (0.39 in).
5. Ensure that the module frame (C-shape) overlaps the insertion profiles by at least 15 mm (0.59 in).
6. Ensure insertion profile thickness and tolerances suit module thickness.

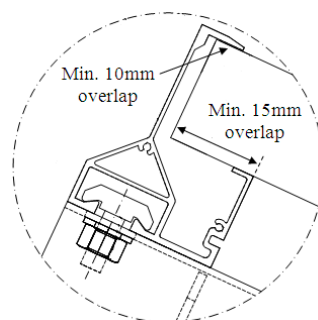

Insertion Method A	Insertion Method B	Insertion Method C
Two insertion profiles run parallel to long side frame.	Two insertion profiles run perpendicularly to long side frame.	An additional support bar used with clamps

Installation Method Module Types	Insertion Method A	Insertion Method B	Insertion Method C
CS3U/CS6U	+5400Pa/-2400Pa	+1400Pa/-1400Pa	+5400Pa/-2400Pa
CS3K/CS6K/CS6V/CS1V/CS1VL	+4000Pa/-2400Pa	+2000Pa/-2000Pa	+5400Pa/-2400Pa
CS6A/CS6VL	+4000Pa/-2400Pa	+2400Pa/-2400Pa	+5400Pa/-2400Pa
CS1K/CS1H	+2400Pa/-2400Pa	/	+5400Pa/-2400Pa
CS3W	/	+1200Pa/-1200Pa	/
CS3L	/	+2200Pa/-2200Pa	/
CS1Y	+5400Pa/-2400Pa	+1800Pa/-1800Pa	/
CS3N	/	+1600Pa/-1600Pa	/

6.4 MOUNTING METHODS WITH SINGLE-AXIS TRACKER

- The bolts and clamps used in this section should follow the requirements in 6.1 and 6.2.
- Under any conditions the junction box should not become in contact with the subjacent racking structure. For any single axis tracker installation method with portrait one row, bearing house cannot be allowed to locate in junction box position.
- If any racking structures, especially bearing house, have to be located under the modules, the gap H between the frame and the racking structure should be

at least 25mm.

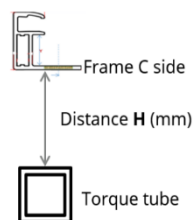

- If your tracker design cannot meet the above distance requirement, please contact Canadian Solar technical support department in writing for advices.

Tracker 1P Bolting method

Install and tighten the module clamps to the mounting rails using the torque stated by the mounting hardware manufacturer. M6 X 1 (1/4") bolt and nut are used for this bolting method.

- Tightening torques should be 6~9 Nm (4.5~6.6 ft-lbs) M6 X 1 (1/4") coarse thread bolts, depending on bolt class.

	Module type	Mounting hole space (mm)	Fixed mounting hole location	Plain washer outer diameter (mm)	Distance H (mm)	Test load (Pa)
<p>The diagram shows a rectangular module layout with mounting holes. The top row has holes labeled C1 and C2. The second row has B1 and B2. The third row has A1 and A2. The fourth row has A3 and A4. The fifth row has B3 and B4. The bottom row has C3 and C4. A 'Torque tube' is shown on the right side, with a dashed line indicating its position relative to the mounting holes.</p>	CS3W-P CS3W-MS	A1-A3: 400	A1, A2, A3, A4	18	>40	+1600/-1600
					≤40	+2400/-2200
	CS3W-P* CS3W-MS*	A1-A3: 400	A1, A2, A3, A4	18	>40	+2400/-2200
		B1-B3: 1155	B1, B2, B3, B4		≤40	+2800/-2400
	CS3Y-P CS3Y-MS CS3S-MS	A1-A3: 400	A1, A2, A3, A4	18	>40	+1600/-1600
					≤40	+2400/-2200
	CS6W-MS	A1-A3: 400	A1, A2, A3, A4	18	>40	+1600/-1600
					≤40	+2000/-1800
	CS7L-MS	A1-A3: 400	A1, A2, A3, A4	18	>40	+1800/-1600
		B1-B3: 790	B1, B2, B3, B4		≤40	+2400/-2100

Note: * means the module with cross bar.

Tracker 1P Clamping method

Module type	B Value (mm)	Clamp length C (mm)	Test load (Pa)
CS3W-P CS3W-MS	400	≥40	+2400/-2200
CS3Y-MS CS3Y-P CS3S-MS CS6W-MS CS7L-MS	400	≥40	+1800/-1600
	600	≥80	+2400/-2200

Tracker 2P Bolting method

Module type	Mounting hole space (mm)	Mounting hole location	Plain washer outer diameter (mm)	Test load(Pa)
CS3W-P CS3W-MS	A1-A3: 400 B1-B3: 1155	B1, B2, A3, A4	18	+1800/-1600
		B1, B2, B3, B4	18	+2400/-2200
CS3W-P* CS3W-MS*	A1-A3: 400 B1-B3: 1155	B1, B2, A3, A4	18	+2400/-2200
CS3Y-P CS3Y-MS CS3S-MS CS6W-MS	A1-A3: 400 B1-B3: 790	B1, B2, A3, A4	18	+1600/-1600
		B1, B2, B3, B4	18	+1800/-1800
CS7L-MS	A1-A3: 400 B1-B3: 790	B1, B2, A3, A4	18	+1800/-1600
		B1, B2, B3, B4	18	+2200/-2200

Note: * means the module with cross bar.

The allowable maximum twist angle of the module is 0.5 degree.

- Please contact the tracker manufacturer and Canadian Solar’s technical support department for details in regard to specific projects

7.0 MAINTENANCE

- **Do not** make modifications to any component of the PV module (diode, junction box, connectors or others).
- Regular maintenance is required to keep modules clear of snow, bird droppings, seeds, pollen, leaves, branches, dirt spots, and dust.
- Modules with sufficient tilt (at least 15°), generally may not require cleaning (rain will have a self-cleaning effect). If the module has become soiled, wash with water and a non-abrasive cleaning implement (sponge) during the cool part of the day. Do not scrape or rub dry dirt away, as this may cause micro scratches.
- Snow should be removed using a soft brush.
- Periodically inspect the system to check the integrity of all wiring and supports.
- To protect against electric shock or injury, electrical or mechanical inspections and maintenance should be performed by qualified personnel only.

8.0 MODULE CLEANING GUIDELINES

This manual covers the requirements for the cleaning procedure of Canadian Solar's photovoltaic modules. The purpose of these cleaning guidelines is to provide general information for cleaning Canadian Solar modules. System users and professional installers should read these guidelines carefully and strictly follow these instructions.

Failure to follow these instructions may result in death, injury or damage to the photovoltaic modules. Damages induced by inappropriate cleaning procedures will void Canadian Solar warranty.



SAFETY WARNING

- Cleaning activities create risk of damaging the modules and array components, as well as increasing the potential electric shock hazard.
- Cracked or broken modules represent an electric shock hazard due to leakage currents, and the risk of shock is increased when modules are wet. Before cleaning, thoroughly inspect modules for cracks, damage, and loose connections.

- The voltage and current present in an array during daylight hours are sufficient to cause a lethal electrical shock.
- Ensure that the circuit is disconnected before starting the cleaning procedure as contact with leakage of electrically active parts can result in injury.
- Ensure that the array has been disconnected to other active components (such as inverter or combiner boxes) before starting with the cleaning.
- Wear suitable protection (clothes, insulated gloves, etc.).
- **Do not** immerse the module, partially or totally, in water or any other cleaning solution.

HANDLING NOTICE

NOTICE

- Use a proper cleaning solution and suitable cleaning equipment.
- **Do not** use abrasive or electric cleaners on the module.
- Particular attention should be taken to avoid the module backsheet or frame to come in contact with sharp objects, as scratches may directly affect product safety.
- **Do not** use abrasive cleaners, de-greasers or any unauthorized chemical substance (e.g. oil, lubricant, pesticide, etc.) on the module.
- **Do not** use cleaning corrosive solutions containing hydrofluoric acid, alkali, acetone, or industrial alcohol. Only substances explicitly approved by Canadian Solar are allowed to be used for cleaning modules.
- Canadian Solar recommends to avoid rotating brush cleaning methods, as they could create micro-cracks in the PV modules.
- Dirt must never be scraped or rubbed away when dry, as this will cause micro-scratches on the glass surface.

OPERATION PREPARATION

- Noticeable dirt must be rubbed away by gentle cleaning implement (soft cloth, sponge or brush with soft bristles).

- Ensure that brushes or agitating tools are not abrasive to glass, EPDM, silicone, aluminum, or steel.
- Conduct the cleaning activities avoiding the hottest hours of the day, in order to avoid thermal stress on the module.

We recommend the following to be used:

- Water with low mineral content
- Near neutral pH water
- The maximum water pressure recommended is 4 MPa (40 bar)

CLEANING METHODS

Method A: Compressed Air

Canadian Solar recommends cleaning the soft dirt (like dust) on modules just with air pressure. This technique can be applied as long as the method is efficient enough considering the existing conditions.

Method B: Wet cleaning

If excessive soiling is present on the module surface, a non-conductive brush, sponge, or other mild agitating method may be used with caution.

- Ensure that any brushes or agitating tools are constructed with non-conductive materials to minimize risk of electric shock and that they are not abrasive to the glass or the aluminum frame.
- If grease is present, an environmental friendly cleaning agent may be used with caution.

ANNEX A: MECHANICAL AND ELECTRICAL RATINGS

Standard Test Conditions are: Irradiance of 1000 W/m², AM1.5 spectrum, and cell temperature of 25°C. The tolerance of electrical characteristics is respectively within ±3% for Pmax, and ±5% for Isc & Voc. Specifications are subject to change without notice.

Table A: Mechanical and electrical ratings under STC

Model Type	Maximum power Pmax <W>	Operating voltage Vmp <V>	Operating current Imp <A>	Open Circuit Voltage Voc <V>	Short Circuit Current Isc <A>	Max. Series Fuse Rating <A>	Overall Dimension <mm>	Weight <Kg>
CS6A-195M	195	24.2	8.04	29.9	8.56	15	1324 x 984 x 40 (52.1 x 38.7 x 1.57 in)	15.5 (34.2 lbs)
CS6A-200M	200	24.3	8.22	30.0	8.74	15		
CS6A-205M	205	24.5	8.38	30.2	8.90	15		
CS6A-210M	210	24.6	8.54	30.3	9.06	15		
CS6A-215M	215	24.7	8.70	30.4	9.22	15		
CS6A-220M	220	24.8	8.87	30.6	9.31	15		
CS6A-205MS	205	24.5	8.37	30.6	9.21	15		
CS6A-210MS	210	24.7	8.50	30.8	9.29	15		
CS6A-215MS	215	24.9	8.63	31.0	9.37	15		
CS6A-220MS	220	25.1	8.76	31.2	9.45	15		
CS6A-225MS	225	25.3	8.91	31.4	9.53	15		
CS6A-230MS	230	25.5	9.02	31.6	9.61	15		
CS6A-235MS	235	25.7	9.14	31.8	9.68	15		
CS6A-240MS	240	25.9	9.27	32.0	9.76	15		
CS6A-245MS	245	26.1	9.39	32.2	9.84	15		
CS6A-195P	195	24.0	8.13	29.6	8.69	15	1324 x 984 x 40 (52.1 x 38.7 x 1.57 in)	15.5 (34.2 lbs)
CS6A-200P	200	24.1	8.30	29.8	8.87	15		
CS6A-205P	205	24.2	8.47	29.9	9.03	15		
CS6A-210P	210	24.3	8.63	30.0	9.19	15		
CS6A-215P	215	24.5	8.78	30.2	9.35	15		
CS6A-220P	220	24.6	8.95	30.4	9.45	15		
CS6U-290P	290	35.9	8.08	44.4	8.64	15	1960 x 992 x 40/35 (77.2 x 39.1 x 1.57/1.38 in)	22.4 (49.4 lbs)
CS6U-295P	295	36.0	8.19	44.5	8.76	15		
CS6U-300P	300	36.1	8.30	44.6	8.87	15		
CS6U-305P	305	36.3	8.41	44.8	8.97	15		
CS6U-310P	310	36.4	8.52	44.9	9.08	15		
CS6U-315P	315	36.6	8.61	45.1	9.18	15		
CS6U-320P	320	36.8	8.69	45.3	9.26	15		
CS6U-325P	325	37.0	8.78	45.5	9.34	15		
CS6U-330P	330	37.2	8.88	45.6	9.45	15		

Model Type	Maximum power Pmax <W>	Operating voltage Vmp <V>	Operating current Imp <A>	Open Circuit Voltage Voc <V>	Short Circuit Current Isc <A>	Max. Series Fuse Rating <A>	Overall Dimension <mm>	Weight <Kg>
CS6U-335P	335	37.4	8.96	45.8	9.54	15		
CS6U-340P	340	37.6	9.05	45.9	9.62	15		
CS6U-345P	345	37.8	9.13	46.0	9.69	15		
CS6U-350P	350	38.1	9.21	46.2	9.79	15		
CS6U-355P	355	38.2	9.30	46.4	9.84	15		
CS6U-360P	360	38.3	9.40	47.0	10.04	15		
CS6U-365P	365	38.5	9.49	47.2	10.13	15		
CS6U-370P	370	38.7	9.57	47.4	10.21	15		
CS6U-375P	375	38.9	9.65	47.6	10.29	15		
CS6U-380P	380	39.1	9.72	47.8	10.36	15		
CS6U-385P	385	39.3	9.80	48.0	10.44	15		
CS6U-390P	390	39.5	9.88	48.2	10.52	15		
CS6U-395P	395	39.7	9.95	48.4	10.59	15		
CS6U-400P	400	39.9	10.03	48.6	10.67	15		
CS6U-405P	405	40.1	10.10	48.8	10.74	15		
CS6U-290M	290	36.3	8.00	44.7	8.51	15	1960 x 992 x 40/35 (77.2 x 39.1 x 1.57/1.38 in)	22.4 (49.4 lbs)
CS6U-295M	295	36.4	8.11	44.9	8.63	15		
CS6U-300M	300	36.5	8.22	45.0	8.74	15		
CS6U-305M	305	36.6	8.33	45.2	8.84	15		
CS6U-310M	310	36.7	8.44	45.3	8.95	15		
CS6U-315M	315	36.9	8.53	45.5	9.04	15		
CS6U-320M	320	37.2	8.61	45.6	9.13	15		
CS6U-325M	325	37.4	8.69	45.8	9.21	15		
CS6U-330M	330	37.5	8.80	45.9	9.31	15		
CS6U-335M	335	37.8	8.87	46.1	9.41	15		
CS6U-340M	340	37.9	8.97	46.2	9.48	15		
CS6U-345M	345	38.1	9.06	46.4	9.56	15		
CS6U-350M	350	38.3	9.14	46.6	9.67	15		
CS6V-200M	200	25.2	7.95	31.1	8.46	15	1638 x 826 x 40 (64.5 x 32.5 x 1.57 in)	16.0 (35.3 lbs)
CS6V-205M	205	25.3	8.11	31.2	8.63	15		
CS6V-210M	210	25.4	8.27	31.3	8.79	15		
CS6V-215M	215	25.5	8.43	31.5	8.94	15		
CS6V-220M	220	25.7	8.56	31.6	9.08	15		
CS6V-225M	225	26.0	8.67	31.8	9.19	15		
CS6V-230M	230	26.1	8.81	31.9	9.33	15		
CS6V-235M	235	26.4	8.91	32.1	9.45	15		

Model Type	Maximum power Pmax <W>	Operating voltage Vmp <V>	Operating current Imp <A>	Open Circuit Voltage Voc <V>	Short Circuit Current Isc <A>	Max. Series Fuse Rating <A>	Overall Dimension <mm>	Weight <Kg>
CS6V-240M	240	26.7	9.00	32.2	9.55	15		
CS6V-245M	245	27.0	9.09	32.4	9.66	15		
CS6V-210MS	210	25.4	8.27	31.5	9.19	15		
CS6V-215MS	215	25.6	8.40	31.7	9.27	15		
CS6V-220MS	220	25.8	8.53	31.9	9.35	15		
CS6V-225MS	225	26.0	8.66	32.1	9.43	15		
CS6V-230MS	230	26.2	8.78	32.3	9.51	15		
CS6V-235MS	235	26.4	8.91	32.5	9.59	15		
CS6V-240MS	240	26.6	9.03	32.7	9.67	15		
CS6V-245MS	245	26.8	9.15	32.9	9.75	15		
CS6V-250MS	250	27.0	9.26	33.1	9.83	15		
CS6V-255MS	255	27.2	9.38	33.3	9.91	15		
CS6VL-150MS	150	19.5	7.70	24.6	9.11	15	1322 x 826 x 40 (52.05 x 32.5 x 1.57 in)	12.6 (27.8 lbs)
CS6VL-155MS	155	19.7	7.87	24.8	9.19	15		
CS6VL-160MS	160	19.9	8.05	25.0	9.27	15		
CS6VL-165MS	165	20.1	8.21	25.2	9.35	15		
CS6VL-170MS	170	20.3	8.38	25.4	9.43	15		
CS6VL-175MS	175	20.5	8.54	25.6	9.51	15		
CS6VL-180MS	180	20.7	8.70	25.8	9.59	15		
CS6VL-185MS	185	20.9	8.86	26.0	9.67	15		
CS6VL-190MS	190	21.1	9.01	26.2	9.75	15		
CS6VL-195MS	195	21.3	9.16	26.4	9.83	15		
CS6VL-200MS	200	21.5	9.31	26.6	9.91	15		
CS6VL-205MS	205	21.7	9.45	26.8	9.99	15		
CS6VL-210MS	210	21.9	9.59	27.6	10.17	15		
CS6VH-115MS	115	13.1	8.78	16.2	9.59	15	844 x 826 x 40 (33.2 x 32.5 x 1.57 in)	9.0 (19.8 lbs)
CS6VH-120MS	120	13.3	9.03	16.36	9.67	15		
CS6VH-125MS	125	13.5	9.26	16.6	9.75	15		
CS6V-190P	190	24.6	7.73	30.6	8.28	15	1638 x 826 x 40 (64.5 x 32.5 x 1.57 in)	16.0 (35.3 lbs)
CS6V-195P	195	24.8	7.87	30.7	8.44	15		
CS6V-200P	200	24.9	8.03	30.8	8.59	15		
CS6V-205P	205	25.0	8.19	30.9	8.76	15		
CS6V-210P	210	25.1	8.35	31.1	8.92	15		
CS6V-215P	215	25.3	8.51	31.2	9.07	15		
CS6V-220P	220	25.5	8.64	31.4	9.21	15		
CS6V-225P	225	25.7	8.75	31.6	9.32	15		

Model Type	Maximum power Pmax <W>	Operating voltage Vmp <V>	Operating current Imp <A>	Open Circuit Voltage Voc <V>	Short Circuit Current Isc <A>	Max. Series Fuse Rating <A>	Overall Dimension <mm>	Weight <Kg>
CS6V-230P	230	25.9	8.90	31.7	9.47	15		
CS6V-235P	235	26.1	8.99	31.8	9.58	15		
CS6K-240P	240	29.9	8.03	37.0	8.59	15	1650 x 992 x 40/35 (65.0 x 39.1 x 1.57/1.38 in)	18.2 (40.1 lbs)
CS6K-245P	245	30.0	8.17	37.1	8.74	15		
CS6K-250P	250	30.1	8.30	37.2	8.87	15		
CS6K-255P	255	30.2	8.43	37.4	9.00	15		
CS6K-260P	260	30.4	8.56	37.5	9.12	15		
CS6K-265P	265	30.6	8.66	37.7	9.23	15		
CS6K-270P	270	30.8	8.75	37.9	9.32	15		
CS6K-275P	275	31.0	8.88	38.0	9.45	15		
CS6K-280P	280	31.3	8.95	38.2	9.52	15		
CS6K-285P	285	31.4	9.06	38.3	9.64	15		
CS6K-290P	290	31.6	9.18	38.5	9.72	15		
CS6K-295P	295	31.8	9.28	38.6	9.81	15		
CS6K-300P	300	32.0	9.38	38.8	9.92	15		
CS6K-305P	305	32.1	9.50	38.9	10.03	15		
CS6K-310P	310	32.3	9.60	39.8	10.22	15		
CS6K-315P	315	32.5	9.70	40.0	10.32	15		
CS6K-320P	320	32.7	9.79	40.2	10.41	15		
CS6K-325P	325	32.9	9.88	40.4	10.50	15		
CS6K-330P	330	33.1	9.97	40.6	10.59	15		
CS6K-335P	335	33.3	10.07	40.8	10.69	15		
CS6K-250M	250	30.4	8.22	37.5	8.74	15	1650 x 992 x 40/35 (65.0 x 39.1 x 1.57/1.38 in)	18.2 (40.1 lbs)
CS6K-255M	255	30.5	8.35	37.7	8.87	15		
CS6K-260M	260	30.7	8.48	37.8	8.99	15		
CS6K-265 M	265	30.9	8.61	37.9	9.11	15		
CS6K-270M	270	31.1	8.67	38.2	9.19	15		
CS6K-275M	275	31.3	8.80	38.3	9.31	15		
CS6K-280M	280	31.5	8.89	38.5	9.43	15		
CS6K-285M	285	31.7	8.98	38.6	9.51	15		
CS6K-290M	290	31.9	9.09	38.7	9.59	15		
CS6K-255MS	255	30.7	8.31	37.9	9.11	15		
CS6K-260MS	260	30.9	8.42	38.1	9.19	15		
CS6K-265MS	265	31.1	8.53	38.3	9.27	15		
CS6K-270MS	270	31.3	8.63	38.5	9.35	15		
CS6K-275MS	275	31.5	8.74	38.7	9.43	15		

Model Type	Maximum power Pmax <W>	Operating voltage Vmp <V>	Operating current Imp <A>	Open Circuit Voltage Voc <V>	Short Circuit Current Isc <A>	Max. Series Fuse Rating <A>	Overall Dimension <mm>	Weight <Kg>
CS6K-280MS	280	31.7	8.84	38.9	9.51	15		
CS6K-285MS	285	31.9	8.94	39.1	9.59	15		
CS6K-290MS	290	32.1	9.05	39.3	9.67	15		
CS6K-295MS	295	32.3	9.14	39.5	9.75	15		
CS6K-300MS	300	32.5	9.24	39.7	9.83	15		
CS6K-305MS	305	32.7	9.33	39.9	9.91	15		
CS6K-310MS	310	32.9	9.43	40.1	9.99	15		
CS6K-315MS	315	33.1	9.52	40.3	10.07	15		
CS6K-320MS	320	33.3	9.61	41.3	10.18	15		
CS6K-325MS	325	33.5	9.71	41.5	10.28	15		
CS6K-330MS	330	33.7	9.80	41.7	10.37	15		
CS6K-335MS	335	33.9	9.89	41.9	10.46	15		
CS3U-350MS	350	38.8	9.03	46.6	9.53	30	2000 x 992 x 40/35 (78.7 x 39.1 x 1.57/1.38 in)	22.6 / 22.5 (49.8 / 49.6 lbs)
CS3U-355MS	355	39.0	9.11	46.8	9.61	30		
CS3U-360MS	360	39.2	9.19	47.0	9.69	30		
CS3U-365MS	365	39.4	9.27	47.2	9.77	30		
CS3U-370MS	370	39.6	9.35	47.4	9.85	30		
CS3U-375MS	375	39.8	9.43	47.6	9.93	30		
CS3U-380MS	380	40.0	9.50	47.8	10.01	30		
CS3U-385MS	385	40.2	9.58	48.0	10.09	30		
CS3U-390MS	390	40.4	9.66	48.2	10.17	30		
CS3U-395MS	395	40.6	9.73	48.4	10.25	30		
CS3U-400MS	400	40.8	9.81	48.6	10.33	30		
CS3U-405MS	405	41.0	9.88	49.3	10.44	30		
CS3U-410MS	410	41.2	9.96	49.5	10.52	30		
CS3U-310P	310	37.2	8.34	44.7	8.88	30	2000 x 992 x 40/35 (78.7 x 39.1 x 1.57/1.38 in)	22.6 / 22.5 (49.8 / 49.6 lbs)
CS3U-315P	315	37.4	8.43	44.9	8.96	30		
CS3U-320P	320	37.6	8.52	45.1	9.04	30		
CS3U-325P	325	37.8	8.60	45.3	9.12	30		
CS3U-330P	330	38.0	8.69	45.5	9.20	30		
CS3U-335P	335	38.2	8.77	45.7	9.28	30		
CS3U-340P	340	38.4	8.86	45.9	9.36	30		
CS3U-345P	345	38.6	8.94	46.1	9.44	30		
CS3U-350P	350	39.2	8.94	46.6	9.51	30		
CS3U-355P	355	39.4	9.02	46.8	9.59	30		
CS3U-360P	360	39.6	9.10	47.0	9.67	30		

Model Type	Maximum power Pmax <W>	Operating voltage Vmp <V>	Operating current Imp <A>	Open Circuit Voltage Voc <V>	Short Circuit Current Isc <A>	Max. Series Fuse Rating <A>	Overall Dimension <mm>	Weight <Kg>
CS3U-365P	365	39.8	9.18	47.2	9.75	30		
CS3U-370P	370	40.0	9.26	47.4	9.83	30		
CS3U-375P	375	40.2	9.34	47.6	9.91	30		
CS3U-380P	380	40.4	9.42	47.8	9.99	30		
CS3U-385P	385	40.6	9.50	48.0	10.07	30		
CS3U-390P	390	40.8	9.56	48.6	10.17	30		
CS3U-395P	395	41.0	9.64	48.8	10.24	30		
CS3U-400P	400	41.2	9.71	49.0	10.30	30		
CS3U-405P	405	41.4	9.79	49.2	10.37	30		
CS3U-410P	410	41.6	9.86	49.4	10.43	30		
CS3U-415P	415	41.8	9.93	49.6	10.49	30		
CS3U-420P	420	42.0	10.00	49.8	10.55	30		
CS3K-280MS	280	31.7	8.84	38.5	9.49	30	1675 x 992 x 40/35 (65.9 x 39.1 x 1.57/1.38 in)	18.5 (40.8 lbs)
CS3K-285MS	285	31.9	8.94	38.7	9.57	30		
CS3K-290MS	290	32.1	9.04	38.9	9.65	30		
CS3K-295MS	295	32.3	9.14	39.1	9.73	30		
CS3K-300MS	300	32.5	9.24	39.3	9.82	30		
CS3K--305MS	305	32.7	9.33	39.5	9.90	30		
CS3K-310MS	310	32.9	9.43	39.7	9.98	30		
CS3K-315MS	315	33.1	9.52	39.9	10.06	30		
CS3K-320MS	320	33.3	9.61	40.1	10.14	30		
CS3K-325MS	325	33.5	9.71	40.3	10.22	30		
CS3K-330MS	330	33.7	9.80	40.5	10.30	30		
CS3K-250P	250	30.0	8.34	36.7	8.98	30	1675 x 992 x 40/35 (65.9 x 39.1 x 1.57/1.38 in)	18.5 (40.8 lbs)
CS3K-255P	255	30.2	8.45	36.9	9.06	30		
CS3K-260P	260	30.4	8.56	37.1	9.14	30		
CS3K-265P	265	30.6	8.66	37.3	9.22	30		
CS3K-270P	270	30.8	8.77	37.5	9.30	30		
CS3K-275P	275	31.0	8.88	37.7	9.38	30		
CS3K-280P	280	31.2	8.98	37.9	9.47	30		
CS3K-285P	285	31.4	9.08	38.1	9.56	30		
CS3K-290P	290	32.3	8.98	38.9	9.49	30.		
CS3K-295P	295	32.5	9.08	39.1	9.57	30.		
CS3K-300P	300	32.7	9.18	39.3	9.65	30.		
CS3K-305P	305	32.9	9.28	39.5	9.73	30.		
CS3K-310P	310	33.1	9.37	39.7	9.81	30.		

Model Type	Maximum power Pmax <W>	Operating voltage Vmp <V>	Operating current Imp <A>	Open Circuit Voltage Voc <V>	Short Circuit Current Isc <A>	Max. Series Fuse Rating <A>	Overall Dimension <mm>	Weight <Kg>
CS3K-315P	315	33.3	9.46	39.9	9.89	30.		
CS3K-320P	320	33.5	9.56	40.1	9.97	30.		
CS3K-325P	325	33.7	9.65	40.9	10.21	30.		
CS3K-330P	330	33.9	9.74	41.1	10.29	30		
CS3K-335P	335	34.1	9.83	41.3	10.37	30		
CS3K-340P	340	34.3	9.92	41.5	10.45	30		
CS3K-345P	345	34.5	10.00	41.7	10.52	30		
CS3K-350P	350	34.7	10.09	41.9	10.60	30		
CS1V-240MS	240	28.3	8.48	34.7	9.15	15	1638 x 826 x 40 (64.5 x 32.5 x 1.57 in)	15.4 (34.0 lbs)
CS1V-245MS	245	28.6	8.58	34.9	9.22	15		
CS1V-250MS	250	28.8	8.68	35.1	9.29	15		
CS1V-255MS	255	29.0	8.79	35.3	9.37	15		
CS1V-260MS	260	29.2	8.89	35.5	9.44	15		
CS1V-265MS	265	29.4	9.00	35.7	9.51	15		
CS1V-270MS	270	29.6	9.11	35.9	9.59	15		
CS1V-275MS	275	29.8	9.22	36.1	9.66	15		
CS1V-280MS	280	30.0	9.33	36.3	9.74	15		
CS1V-285MS	285	30.2	9.44	36.5	9.82	15		
CS1VL-190MS	190	22.5	8.45	27.6	9.10	15	1322 x 826 x 35 (52.05 x 32.5 x 1.38 in)	12.6 (27.8 lbs)
CS1VL-195MS	195	22.7	8.58	27.8	9.22	15		
CS1VL-200MS	200	22.9	8.73	28.0	9.34	15		
CS1VL-205MS	205	23.1	8.88	28.2	9.46	15		
CS1VL-210MS	210	23.3	9.01	28.4	9.58	15		
CS1VL-215MS	215	23.5	9.15	28.6	9.70	15		
CS1VL-220MS	220	23.7	9.28	28.8	9.82	15		
CS1VL-225MS	225	23.9	9.41	29.0	9.97	15		
CS1K-310MS	310	35.2	8.82	43.1	9.37	20	1675 x 992 x 35 (65.9 x 39.1 x 1.38 in)	18.5 (40.8 lbs)
CS1K-315MS	315	35.4	8.91	43.2	9.44	20		
CS1K-320MS	320	35.6	9.00	43.3	9.51	20		
CS1K-325MS	325	35.8	9.09	43.4	9.58	20		
CS1K-330MS	330	36.0	9.18	43.5	9.65	20		
CS1K-335MS	335	36.2	9.27	43.6	9.73	20		
CS1K-340MS	340	36.4	9.35	43.7	9.81	20		
CS1K-345MS	345	36.6	9.43	43.8	9.88	20		
CS1K-350MS	350	36.8	9.51	43.9	9.95	20		
CS1K-355MS	355	37.0	9.60	44.0	10.02	20		

Model Type	Maximum power Pmax <W>	Operating voltage Vmp <V>	Operating current Imp <A>	Open Circuit Voltage Voc <V>	Short Circuit Current Isc <A>	Max. Series Fuse Rating <A>	Overall Dimension <mm>	Weight <Kg>
CS1H-325MS	325	36.6	8.88	44.1	9.64	16	1700 x 992 x 35 (66.9 x 39.1 x 1.38 in)	19.2 (42.3 lbs)
CS1H-330MS	330	37.0	8.92	44.2	9.68	16		
CS1H-335MS	335	37.4	8.96	44.3	9.72	16		
CS1H-340MS	340	37.8	9.00	44.5	9.76	16		
CS1H-345MS	345	38.2	9.04	44.6	9.80	16		
CS1U-385MS	385	43.5	8.86	53.1	9.45	15	2078 x 992 x 35 (81.8 x 39.1 x 1.38 in)	23.4 (51.6 lbs)
CS1U-390MS	390	43.7	8.93	53.2	9.50	15		
CS1U-395MS	395	43.9	9.01	53.3	9.55	15		
CS1U-400MS	400	44.1	9.08	53.4	9.60	15		
CS1U-405MS	405	44.3	9.16	53.5	9.65	15		
CS1U-410MS	410	44.5	9.23	53.6	9.70	15		
CS1U-415MS	415	44.7	9.30	53.7	9.75	15		
CS1U-420MS	420	44.9	9.37	53.8	9.80	15		
CS1U-425MS	425	45.1	9.44	53.9	9.85	15		
CS1U-430MS	430	45.3	9.51	54.0	9.90	15		
CS1Y-380MS	380	42.7	8.89	51.5	9.74	16	2021 x 996 x 35 (79.6 x 39.2 x 1.38 in)	24.0 (52.9 lbs)
CS1Y-385MS	385	42.9	8.97	51.7	9.78	16		
CS1Y-390MS	390	43.1	9.05	51.9	9.82	16		
CS1Y-395MS	395	43.3	9.13	52.1	9.86	16		
CS1Y-400MS	400	43.5	9.20	52.3	9.90	16		
CS1Y-405MS	405	43.7	9.27	52.5	9.94	16		
CS1Y-410MS	410	43.8	9.37	52.7	9.98	16		
CS1Y-415MS	415	44.0	9.44	52.8	10.02	16		
CS3W-385P	385	38.1	10.11	46.6	10.66	20	2108 x 1048 x 40/35 (83.0 x 41.3 x 1.57/1.38 in)	24.3 (53.6lbs)
CS3W-390P	390	38.3	10.19	46.8	10.74	20		
CS3W-395P	395	38.5	10.26	47.0	10.82	20		
CS3W-400P	400	38.7	10.34	47.2	10.90	20		
CS3W-405P	405	38.9	10.42	47.4	10.98	20		
CS3W-410P	410	39.1	10.49	47.6	11.06	20		
CS3W-415P	415	39.3	10.56	47.8	11.14	20		
CS3W-420P	420	39.5	10.64	48.0	11.26	20		
CS3W-425P	425	39.7	10.71	48.2	11.29	20		
CS3W-430P	430	39.9	10.78	48.4	11.32	20		
CS3W-435P	435	40.1	10.85	48.6	11.35	20		
CS3W-440P	440	40.3	10.92	48.7	11.40	20		
CS3W-445P	445	40.5	10.99	48.8	11.45	20		

Model Type	Maximum power Pmax <W>	Operating voltage Vmp <V>	Operating current Imp <A>	Open Circuit Voltage Voc <V>	Short Circuit Current Isc <A>	Max. Series Fuse Rating <A>	Overall Dimension <mm>	Weight <Kg>
CS3L-320P	320	31.8	10.07	38.8	10.66	20	1765 x 1048 x 40/35 (69.5 x 41.3 x 1.57/1.38 in)	20.5 (45.2lbs)
CS3L-325P	325	32.0	10.16	39.0	10.74	20		
CS3L-330P	330	32.2	10.24	39.2	10.82	20		
CS3L-335P	335	32.4	10.34	39.4	10.90	20		
CS3L-340P	340	32.6	10.43	39.6	10.98	20		
CS3L-345P	345	32.8	10.52	39.8	11.06	20		
CS3L-350P	350	33.0	10.61	40.2	11.24	20		
CS3L-355P	355	33.2	10.70	40.4	11.31	20		
CS3L-360P	360	33.4	10.78	40.6	11.37	20		
CS3L-365P	365	33.6	10.87	40.8	11.44	20		
CS3W-415MS	415	39.7	10.46	47.7	11.22	20	2108 x 1048 x 40/35 (83.0 x 41.3 x 1.57/1.38 in)	24.3 (53.6lbs)
CS3W-420MS	420	39.9	10.53	47.9	11.27	20		
CS3W-425MS	425	40.1	10.60	48.1	11.32	20		
CS3W-430MS	430	40.3	10.68	48.3	11.37	20		
CS3W-435MS	435	40.5	10.75	48.5	11.42	20		
CS3W-440MS	440	40.7	10.82	48.7	11.48	20		
CS3W-445MS	445	40.9	10.89	48.9	11.54	20		
CS3W-450MS	450	41.1	10.96	49.1	11.60	20		
CS3W-455MS	455	41.3	11.02	49.3	11.66	20		
CS3W-460MS	460	41.5	11.09	49.5	11.72	20		
CS3W-465MS	465	41.7	11.16	49.7	11.78	20		
CS3W-470MS	470	41.9	11.22	49.9	11.84	20		
CS3L-345MS	345	33.1	10.43	39.8	11.23	20	1765 x 1048 x 40/35 (69.5 x 41.3 x 1.57/1.38 in)	20.5 (45.2 lbs)
CS3L-350MS	350	33.3	10.52	40.0	11.28	20		
CS3L-355MS	355	33.5	10.61	40.2	11.33	20		
CS3L-360MS	360	33.7	10.69	40.4	11.40	20		
CS3L-365MS	365	33.9	10.78	40.6	11.47	20		
CS3L-370MS	370	34.1	10.86	40.8	11.54	20		
CS3L-375MS	375	34.3	10.94	41.0	11.61	20		
CS3L-380MS	380	34.5	11.02	41.2	11.68	20		
CS3L-385MS	385	34.7	11.10	41.4	11.75	20		
CS3L-390MS	390	34.9	11.18	41.6	11.82	20		
CS3LA-290MS	290	26.9	10.78	32.5	11.47	20	1424 x 1048 x 35 (56.1 x 41.3 x 1.38 in)	17.0 (37.5 lbs)
CS3LA-295MS	295	27.2	10.86	32.6	11.54	20		
CS3LA-300MS	300	27.4	10.94	32.8	11.61	20		
CS3LA-305MS	305	27.7	11.02	33.0	11.68	20		

Model Type	Maximum power Pmax <W>	Operating voltage Vmp <V>	Operating current Imp <A>	Open Circuit Voltage Voc <V>	Short Circuit Current Isc <A>	Max. Series Fuse Rating <A>	Overall Dimension <mm>	Weight <Kg>
CS3LB-240MS	240	22.4	10.71	27.1	11.47	20	1765 x 709 x 35 (69.5 x 27.9 x 1.38 in)	14.5 (32.0 lbs)
CS3LB-245MS	245	22.7	10.82	27.2	11.54	20		
CS3LB-250MS	250	22.9	10.94	27.3	11.61	20		
CS3LB-255MS	255	23.1	11.05	27.5	11.72	20		
CS1HA-265MS	265	29.9	8.86	36.1	9.45	15	1395 x 992 x 35 (54.9 x 39.1 x 1.38 in)	15.8 (34.8lbs)
CS1HA-270MS	270	30.3	8.92	36.3	9.49	15		
CS1HA-275MS	275	30.6	8.99	36.5	9.53	15		
CS1HA-280MS	280	30.9	9.07	36.8	9.57	15		
CS1HA-285MS	285	31.2	9.14	37.2	9.61	15		
CS3Y-420P	420	41.2	10.20	50.4	10.98	20	2252 x 1048 x 35 (88.7 x 41.3 x 1.38 in)	25.7 (56.7 lbs)
CS3Y-425P	425	41.4	10.27	50.6	11.03	20		
CS3Y-430P	430	41.6	10.34	50.8	11.08	20		
CS3Y-435P	435	41.8	10.41	51.0	11.13	20		
CS3Y-440P	440	42.0	10.48	51.2	11.18	20		
CS3Y-445P	445	42.2	10.55	51.4	11.23	20		
CS3Y-450P	450	42.4	10.62	51.6	11.28	20		
CS3Y-455P	455	42.6	10.69	51.8	11.33	20		
CS3Y-460P	460	42.8	10.75	52.0	11.38	20		
CS3Y-465P	465	43.0	10.82	52.2	11.43	20		
CS3Y-470P	470	43.2	10.88	52.4	11.48	20		
CS3Y-475P	475	43.4	10.95	52.6	11.53	20		
CS3Y-480P	480	43.6	11.01	52.8	11.58	20		
CS3Y-485P	485	43.8	11.08	53.0	11.63	20		
CS3Y-490P	490	44.0	11.14	53.2	11.68	20		
CS3Y-495P	495	44.2	11.20	53.4	11.73	20		
CS3Y-465MS	465	43.6	10.67	52.3	11.42	20	2252 x 1048 x 35 (88.7 x 41.3 x 1.38 in)	25.7 (56.7 lbs)
CS3Y-470MS	470	43.8	10.74	52.5	11.47	20		
CS3Y-475MS	475	44.0	10.81	52.7	11.52	20		
CS3Y-480MS	480	44.2	10.87	52.9	11.57	20		
CS3Y-485MS	485	44.4	10.94	53.1	11.62	20		
CS3Y-490MS	490	44.6	11.00	53.3	11.67	20		
CS3Y-495MS	495	44.8	11.06	53.5	11.72	20		
CS3Y-500MS	500	45.0	11.12	53.7	11.77	20		
CS3Y-505MS	505	45.2	11.18	53.9	11.82	20		
CS3Y-510MS	510	45.4	11.24	54.1	11.87	20		

Model Type	Maximum power Pmax <W>	Operating voltage Vmp <V>	Operating current Imp <A>	Open Circuit Voltage Voc <V>	Short Circuit Current Isc <A>	Max. Series Fuse Rating <A>	Overall Dimension <mm>	Weight <Kg>
CS3S-425MS	425	43.9	9.69	52.5	10.34	20	2168 x 996 x 35 (85.4 x 39.2 x 1.38 in)	23.7 (52.2 lbs)
CS3S-430MS	430	44.1	9.76	52.7	10.40	20		
CS3S-435MS	435	44.3	9.82	52.9	10.46	20		
CS3S-440MS	440	44.5	9.89	53.1	10.52	20		
CS3S-445MS	445	44.7	9.96	53.3	10.58	20		
CS3S-450MS	450	44.9	10.03	53.5	10.64	20		
CS3N-385MS	385	36.6	10.52	43.9	11.32	20	1940 x 1048 x 35 (76.4 x 41.3 x 1.38 in)	22.5 (49.6 lbs)
CS3N-390MS	390	36.8	10.60	44.1	11.38	20		
CS3N-395MS	395	37.0	10.68	44.3	11.44	20		
CS3N-400MS	400	37.2	10.76	44.5	11.50	20		
CS3N-405MS	405	37.4	10.83	44.7	11.56	20		
CS3N-410MS	410	37.6	10.92	44.9	11.62	20		
CS3N-415MS	415	37.8	10.98	45.1	11.68	20		
CS3N-420MS	420	38.0	11.06	45.3	11.74	20		
CS3N-425MS	425	38.2	11.13	45.5	11.80	20		
CS6W-515MS	515	40.3	12.78	48.2	13.65	25	2261 x 1134 x 35 (89.0 x 44.6 x 1.38 in)	28.2 (62.2 lbs)
CS6W-520MS	520	40.5	12.84	48.4	13.70	25		
CS6W-525MS	525	40.7	12.90	48.6	13.75	25		
CS6W-530MS	530	40.9	12.96	48.8	13.80	25		
CS6W-535MS	535	41.1	13.02	49.0	13.85	25		
CS6W-540MS	540	41.3	13.08	49.2	13.90	25		
CS6W-545MS	545	41.5	13.14	49.4	13.95	25		
CS6W-550MS	550	41.7	13.20	49.6	14.00	25		
CS6W-555MS	555	41.9	13.25	49.8	14.05	25		
CS6W-560MS	560	42.1	13.31	50.0	14.10	25		
CS7N-635MS	635	37.3	17.03	44.4	18.27	30	2384 x 1303 x 35 (93.9 x 51.3 x 1.38 in)	34.4 (75.8 lbs)
CS7N-640MS	640	37.5	17.07	44.6	18.31	30		
CS7N-645MS	645	37.7	17.11	44.8	18.35	30		
CS7N-650MS	650	37.9	17.16	45.0	18.39	30		
CS7N-655MS	655	38.1	17.20	45.2	18.43	30		
CS7N-660MS	660	38.3	17.24	45.4	18.47	30		
CS7N-665MS	665	38.5	17.28	45.6	18.51	30		
CS7L-575MS	575	33.9	16.97	40.3	18.22	30	2172 x 1303 x 35 (85.5 x 51.3 x 1.38 in)	31.4 (69.2 lbs)
CS7L-580MS	580	34.1	17.02	40.5	18.27	30		
CS7L-585MS	585	34.3	17.06	40.7	18.32	30		
CS7L-590MS	590	34.5	17.11	40.9	18.37	30		

Model Type	Maximum power Pmax <W>	Operating voltage Vmp <V>	Operating current Imp <A>	Open Circuit Voltage Voc <V>	Short Circuit Current Isc <A>	Max. Series Fuse Rating <A>	Overall Dimension <mm>	Weight <Kg>
CS7L-595MS	595	34.7	17.15	41.1	18.42	30		
CS7L-600MS	600	34.9	17.20	41.3	18.47	30		
CS7L-605MS	605	35.1	17.25	41.5	18.52	30		

- The recommended maximum series fuse rating is stated in table A above.

AMENDED EDITIONS AND DATES

- Rev 1.6 was amended and released on Apr, 2019
- Rev 1.7 was amended and released on May, 2019
- Rev 1.8 was amended and released on Sep, 2019
- Rev 1.9 was amended and released on Oct, 2019
- Rev 2.0 was amended and released on Dec, 2019
- Rev 2.1 was amended and released on Apr, 2020
- Rev 2.2 was amended and released on July, 2020
- Rev 2.3 was amended and released on Oct, 2020
- Rev 2.4 was amended and released on Jan, 2021
- Rev 2.5 was amended and released on March, 2021
- Rev 2.6 was amended and released on April, 2021
- Rev 2.61 was amended and released on April, 2021
- Rev 2.62 was amended and released on April, 2021

CSI Solar Co., Ltd.

199 Lushan Road, SND, Suzhou, Jiangsu, China, 215129

www.csisolar.com